

Josts

JP2500

**Hand Pallet Trolley
(2500 Kg.)**



- Low maintenance costs because of fewer breakdowns
- Built-in overload valve and totally sealed hydraulic pump, seals of hydraulic pump are imported from Germany
- Heavy duty one piece "c" section forks for greatest strength and durability

- Nylon entry rollers prevent physical exertion of the operator and protect load wheels and pallet

- Easy and quick lowering
- Effortless lifting



The JP 2500 hydraulic pallet trolley lifts and transports 2500 kg pallet loads effortlessly. The trolley is invaluable for use inside factories, warehouses, docks, railway workshops and wherever pallets are to be transported, in the most efficient and reliable way.



**BUREAU
VERITAS**

JP2500

Technical Data

Capacity	Kgs	2500 kgs
Fork length	l	1150 mm
Width over forks	m	550 mm (685mm optn.)
Turning radius	Wa	1274 mm
Fork width	n	160 mm
Width between forks		230/365 mm
Height of forks (lowered)	s	85 mm
Lift	h	110 mm
Load Centre	C	600 mm
Drive wheel (Nylon)		200 Ø x 50 mm
Load wheel (Nylon)		80 Ø x 70 mm
Weight of one trolley		90 kgs
Overall length (L)		1550

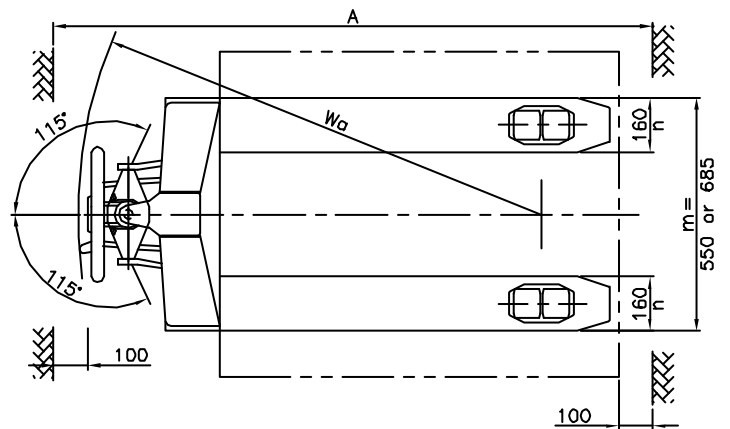
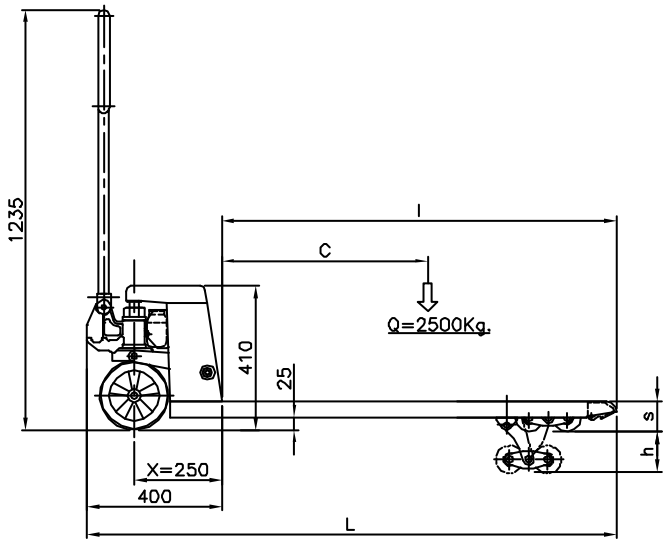

Entry Rollers facilitate easy and smooth entry of forks inside the pallet.



The heart of the JP 2500 is the 2.5 ton hydraulic pump unit with a sealed fluid system that is fully airtight. The pump is equipped with an overload relief valve to avoid misuse due to overloading



The ergonomically designed handle has a release lever (Operated through a control rod and chain) which has three distinct operating positions: 'upward' for lowering, 'normal' for drive, and 'lowered' for lifting'



Regular trolleys are fitted with Polymer drive and load wheels. Cast iron wheels can also be provided as optional.

Authorised Dealer

Josts

Jost's Engineering Company Limited

60 Sir Phirozeshah Mehta Road Mumbai 400 001,
Phone: 22661150, Fax: 22661951
E-mail: jostsho@josts.in, Web site: www.josts.com

Sales Offices : C-7 Wagle Industrial Estate Road 12
Thane 400 604 Phone : 25833974, 25821727/46/48/2083
Fax : 25823478 E-mail: salesthane@josts.in

Bangalore: 080-22263707, Baroda 0265-2351642, Chennai : 044-26268536,
Kolkata 033-22482257 New Delhi : 011- 29839446 Pune: 020-25436601, Secunderabad : 040-27714934