

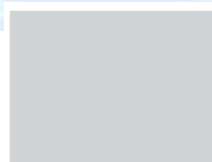

# JORACK

Storage Solutions from

Design to Installations





## Profile

Jorack, the range of Industrial racks from Josts is a perfect storage solution for all types of items, as the design allows the span to be configured as per the specific requirement. This creates maximum storage capacity with minimum loss of space. Jorack is ideal for all type of loads of varying size and types. Jorack has been installed in various segments of industry such as Engineering, Auto & Ancillaries, Defence, Chemical, Pharmaceutical, Railways, Consumer items, Breweries & Beverages, Food & Processing, Paint, Paper, Metal, Textile, Telecom, Retail, Rubber & Tyres, Power, Packaging, Refractories, Electrical & Electronics, Port, Logistics etc.

## Quality

Jorack storage racks are steadfast in answering the changing needs of the industry. It's superior quality is ensured with precise manufacturing from high quality grade steel sheets. The column and span sections are rolled and punched to precise dimensions to very close tolerances. All profiles are then pre-treated chemically by seven tank phosphating method for increased life. The special powder coating ensures elegant finish and durability. The unique lip configuration of beam section ensures high strength with reduced overall weight.

ISO 9001

BUREAU VERITAS  
Certification



## Light Duty Jorack Shelving

Light Duty Racking System is useful for small parts and spares stored on shelves. This type of shelving is easy to adapt, with cross members quickly unbolted or unclipped and shelves can be adjusted to any level.

### FEATURES :

- Flexible to suit customers specification.
- Load carriage capacity up to 250 kg per level.
- Rolled formed profile for solid build.
- Press formed deck panels for flat surface and good load carrying capacity.
- Chemically treated for de-greasing and de-rusting using hot phosphating method for better endurance and durability.
- Optional powder coated body for a fine finish and prolonged rust-free life even in humid zones.
- Comes in a kit form for easy to assemble, dismantle and transportation.



### Sway Arrestors

Slotted Angle Racks have Sway Arrestors which provides increased stability.

### Corner Support

It Provides increased fixity between the shelf & the angle and also aids in prevention of shaking loading.

### Slotted Angle

40 X 40 X 2 mm 60 X 40 X 2 mm  
60 X 40 X 2.5 mm 80 X 40 X 2.5 mm  
Also Available in Standard Lengths  
6', 6.5', 7', 8.25' (Feet)

### Shelves

900 X 300 mm 900 X 375 mm  
900 X 450 mm 900 X 600 mm  
\*Sheet Thickness will vary based on  
Load Requirements.



## Medium Duty Jorack Shelving

Medium Duty Jorack shelving are modular frame and beam shelving system catering to large and bulk items. Medium duty racks are constructively similar to light pallet racking but designed to store non-palletized goods. This is an intermediate application between light and heavy-duty applications. Long span shelving is designed for loading / unloading goods manually without mechanical equipment. Stored goods can be from smallest components to large and awkwardly shaped items. It can be customized as per the specific requirements of our clients.

### FEATURES :

- Available in wide range of sizes and duties for load capacities from 500 – 1000 kg per level.
- Rolled formed profile for solid build.
- Press formed deck panels for flat surface and good load carrying capacity.
- Chemically treated for de-greasing & de-rusting using hot phosphating method for better endurance and durability.
- Optional powder coated body for a fine finish and prolonged rust-free life even in humid zones.
- Easily configurable to meet the required load volume and handling requirements.
- Adjustable beam levels for varying item sizes.



## Heavy Duty Jorack For Pallet Racking

Heavy duty Jorack for pallet racking are basically conventional or adjustable pallet racking, which are the most widely used storage system for all palletized and non-palletized loads. Both single or double-sided runs of racking are separated by aisles which can be sized to suit the customers existing material handling equipments. Jorack is widely specified in virtually every industry and can easily adapt to the vast range of products to be stored.

As all beams are height adjustable and the storage system is easy to install, Heavy duty Jorack is highly versatile, giving direct access to all individual pallets optimizing space and efficiency, providing real long term value for money. Separate panel shelves can be used to accommodate non-palletized loads

### FEATURES :

- 100% accessibility to individual pallets.
- Load capacity from 500 – 2000 kg per pallet.
- High degree of system adjustability to suit any pallet type.
- Optimises available space for maximum storage capacity.
- Suitable for use with conventional Forklift trucks / Stackers.
- Easy to install or reposition.



## Mezzanine Floors

A Mezzanine floor is essentially a raised platform that is supported by steel columns and is totally independent of the host building. It allows to create additional floor space from wasted air space above existing work and storage areas and can be used to create extra space for office, storage, production or even retail space. This may double or even triple the amount of space available. They are probably the most cost-effective and efficient means of significantly increasing the floor space and storage capacity. They can be easily relocated with minimal disruption.

### FEATURES :

- Cost-efficient increased space.
- Capacity from 200 - 1500 kg per square meter.
- Fully dismantable and relocatable at a later date.
- Seamless integration, within existing environment.

- Light weight, economic steel structure.
- Flexible design option to meet precise customer requirements.
- Can be provided with goods lift as an option.
- High quality, powder coated accessories in a wide choice of colors.
- Can be provided with good ventilation and fire protection system.

## Multi-Tier Jorack

Multi-Tier Jorack is a two-in-one solution where space is at premium. They are a perfect choice for commercial and industrial locations. The design optimizes the available vertical space and offers instant access to stock. Depending on the the available warehouse clear height, 2-3 levels of storage space can be incorporated normally doubling or tripling the available floor area. The various levels can be easily accessed via gangway located between the shelves and the gangway can be reached either through stairs or lifts. Various choices of Multi-tier can be offered as mentioned below.

### FEATURES :

- Capacity from 200 – 1200 kg per square meter.
- **Short and Medium Span Shelving:** Open, closed and medium span bays of high-rise shelving can be combined in the same unit, enabling the efficient storage of a wide variety of items.
- **Over-Rack Platform:** It can be constructed above single tier, using the shelving structure to support the floor.
- **Multi-Tier Shelving:** Each tier of shelving is accessed by a walkway, served by stairways.
- **High-Rise Shelving:** It can be installed upto heights of 15 meeter or more to maximize the use of available warehouse height.



## Cantilever Jorack

Cantilever Joracks are a superior storage solution in many situations. They are ideal for storage of long products and are widely used for storing Rods, Pipes, Channel and other rolled items.

### FEATURES :

- Capacity from 500–4000 kg per level and height up to 6 meters.
- With no front column in the way, Cantilever Joracks are faster to load / unload and lowers the handling time and costs.
- Loads can be placed anywhere along the entire length of a row on the Cantilever Jorack.
- The lack of front column saves horizontal space that is normally lost do to rack structure. Handling clearance is also more abundant.
- Any load or storage slot is immediately accessible.
- Both reduced handling times and increased space utilisation helps make Cantilever Joracks more cost-efficient.



## VNA Jorack

Josts offers turnkey projects on high rise very narrow aisle (VNA) racking solutions, where high dense storage and direct accessibility to all pallets is required. The design adheres to Indian and International codes from design to erection, hence ensures high level of quality, safety and durability. Josts offers best after sales service and helps their client to maintain their storage racks in perfect shape. VNA Joraks are suitable for both pallet stacking as well as order picking. Guide rail is provided as optional feature along with VNA Joracks. The racks can provided with 1500 kg load capacity per pallet and height up to 17 meters.



## Drive-in Jorack

When block stacking is not an option, the Drive-in Jorack is ideal for filling large areas of a warehouse with multi-deep, multi-wide and multi-high blocks of pallets.

Drive-in Jorack is usually specified for first-in-first-out & first-in-last-out storage situations. This will be ideal solution where the variation of loads are minimum and all loads are uniform in nature. Cold stores often specify this type of racking as it an ideal method when storing predictable batch movements of palletized loads.

The System provides blocks of static storage where pallets are stored two or more deep. It offers restricted selectivity of individual pallets but provides effective high density storage with good use of the 'cube'. The continuous blocks of racking (no aisles) allows for truck access directly into the system placing goods next in line, one behind the other on cantilevered rails each side of the lane. Guide Rails isolated form super-structure can be provided on the floor within the racking system to guide the MHE (material handling equipments) safely, preventing them from hitting the super-structure.

# Customer Details Required



Customer Details Required For Storage Solutions	
Type of load	Palletised / Non-palletised / Both
Type of Pallet	Reversible / Non-Reversible Pallets
Size of Pallet	Length / Width / Height (In mm)
Pallet Unit Load	Pallet Weight + Load Weight (in kg)
Floor Dimension	Length / Width (in mm)
Aisle Width Available	Pallet to Pallet (in mm)
Warehouse Clear Height	Height (in mm)
Equipment to be Used	Existing / New with details
Equipment Width	In mm
Straddle Width	In mm
Please forward the Floor Layout	In Auto-Cad Format

Jost's engineers can visit and discuss with the users to understand their exact requirements, conduct site survey and offer proper guidance.

## Sectional Details

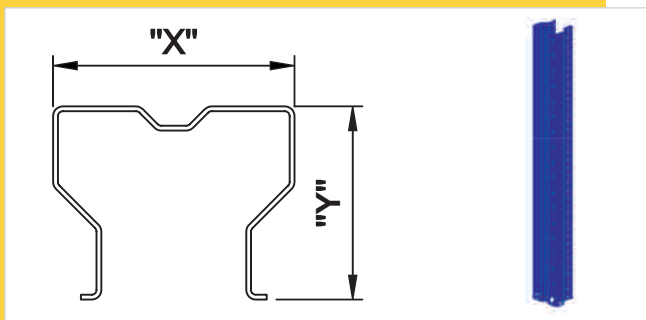

### HEAVY DUTY UPRIGHT:

- Josts Heavy duty upright is 12 bend roll formed section, powder coated finish up to 6500 mm and GI without Powder Coated from 6600 mm to 17000 mm., available in the range of 1.6, 2 and 2.4 mm thickness.
- Loading level can be adjusted in the pitch of 85mm.

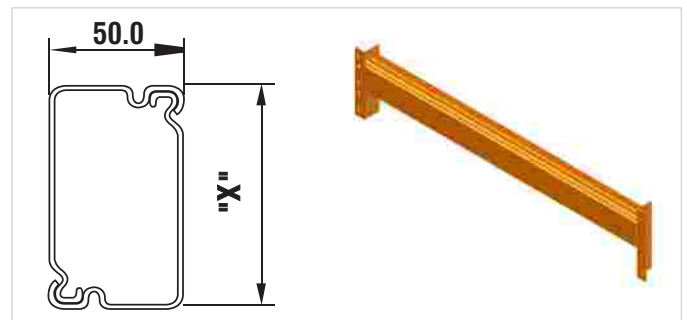

### HEAVY DUTY BEAM:

- Heavy duty beam are rolled form box section.
- Beams available with the end connectors which gives the versatility of varying the heights.
- Ends of the beam is provided with 3 & 4 lips and two bolts to ensure rigidity.
- "X" dimension varies according to the load.

**Bengaluru :** +91.80.2226 3707 / 22263708  
**Chennai :** +91.44. 2626 8536 / 2628 8407  
**Delhi :** +91.11.4567 6000 / 14  
**Kolkata :** +91.33.2242 9510  
**Pune :** +91.20.2543 4350 / 90  
**Secunderabad :** +91.40.2771 4934 / 44 / 54  
**Vadodara :** +91.265.2351 642



Since 1907

### Jost's Engineering Company Limited

C-7 Wagle Industrial Estate, Road No. 12, Thane - 400 604. Maharashtra. INDIA.  
 T.: +91.22.6117 4000 / 2582 1727 F.: +91.22.6117 4020 E.: infomhe@josts.in